

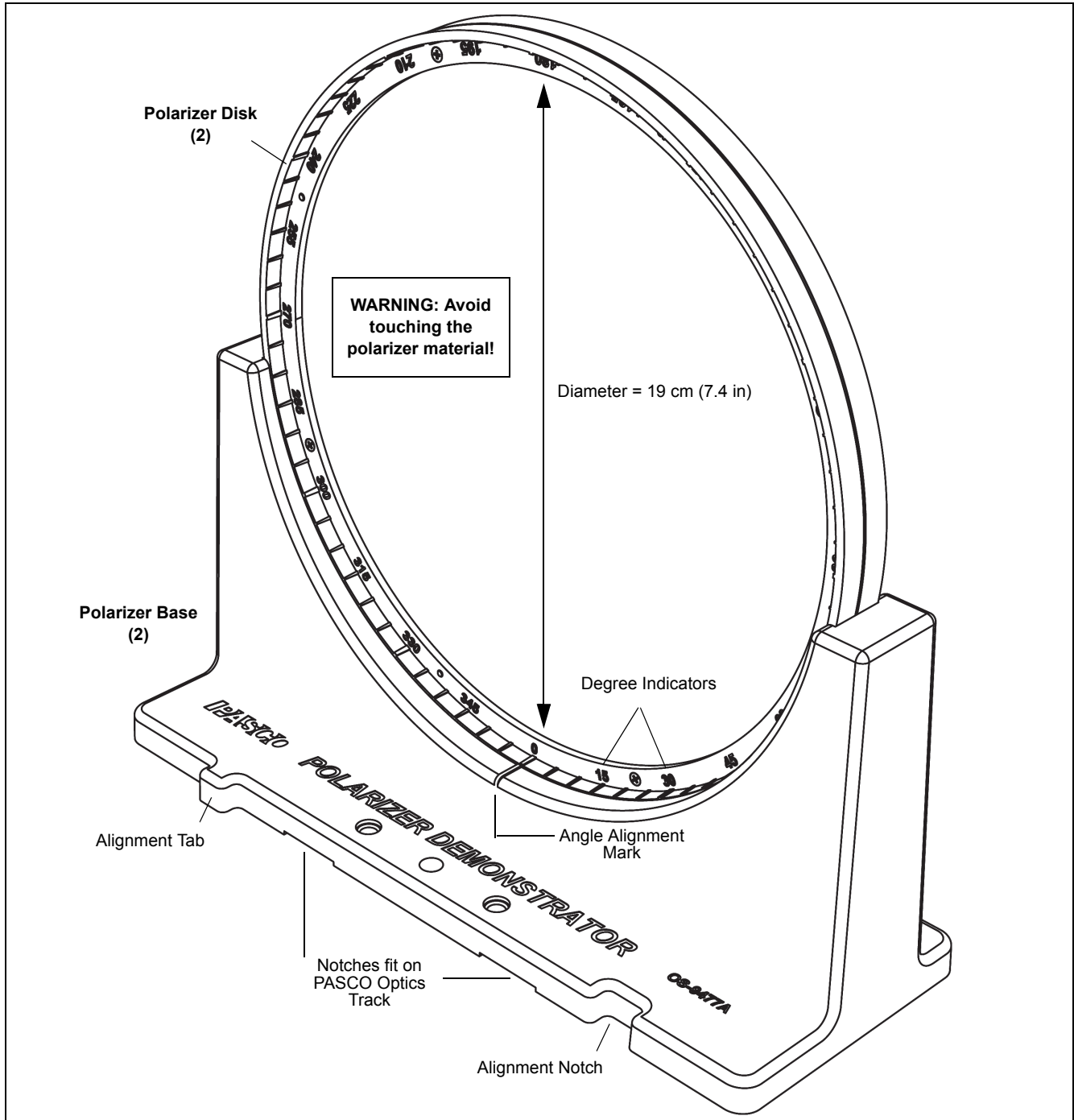

# Polarizer Demonstrator

OS-9477A



## Polarizer Demonstrator (OS-9477A)

Included Items	Quantity
Polarizer Disk	2
Polarizer Base	2

### Recommended Items\*

PASCO 60 cm Optics Track (OS-8541)
PASCO 1.2 m Optics Track (OS-8508)
Polarizer Demonstrator Accessory (OS-8172)

\*See the PASCO catalog or web site at [WWW.PASCO.COM](http://WWW.PASCO.COM)

## Introduction

The Polarizer Demonstrator can be used for easily visible classroom demonstrations. They can show how the intensity of transmitted light through two polarizers varies with the angle of one polarizer compared to the other. The Polarizer Demonstrator can be used to investigate stress distribution patterns by viewing clear plastic objects between crossed polarizers.

The Polarizer Demonstrator has two Polarizer Disks and two Polarizer Bases. The plastic frame of the Polarizer Disk has degree indicators every five degrees. The plastic frame fits into the curved portion of the Polarizer Base and can be rotated easily in the base. The Polarizer Base has an Angle Alignment Mark on both sides. The base has notches on its bottom edge that fit on top of a PASCO Optics Track. Each base also has an alignment tab and an alignment notch on both sides. The base has two threaded holes (1/4" - 20 threads per inch) for mounting accessories, and a hole that can be used to attach the base to an optics track if necessary (mounting hardware not included).

**WARNING:** Handle the Polarizer Disks carefully. Avoid touching the polarizer material of the Polarizer Disk.

### Cleaning

To remove finger prints from the polarizer material, use only lens cleaning tissue or a soft cloth that is specifically designed for cleaning eyeglasses. Do not put liquids on the polarizer material.

## Setup

1. Place each Polarizer Disk in a Polarizer Base. Place the bases so that the alignment tabs fit into the alignment notches.

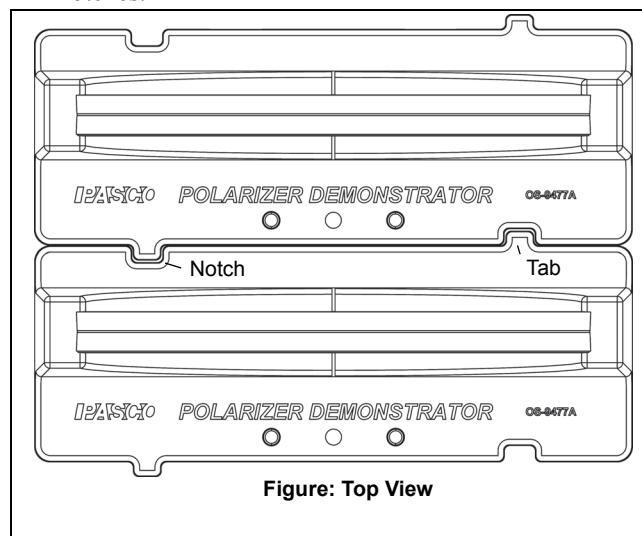
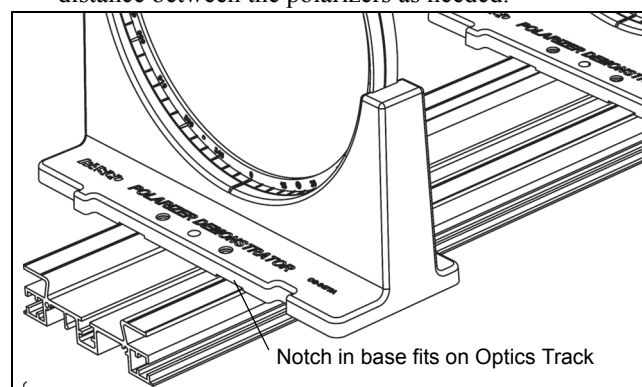

Figure: Top View

2. **For use with a PASCO Optics Track:** Place each Polarizer Disk into a Polarizer Base. Place both bases on the PASCO Optics Track so that the notches in the bottom of the bases fit on top of the optics track. Adjust the distance between the polarizers as needed.



## Operation

Set each Polarizer Disk so that the zero degree mark is next to the angle alignment mark on the Polarizer Base. Look through both disks at an object or light source. Slowly turn one of the Polarizer Disks and observe what happens to the intensity of light transmitted through the disks. Note the angle of the disk that you turned. Continue turning the Polarizer Disk until the 180 degrees mark is next to the angle alignment mark on the base. Compare the intensity of light transmitted through the disks to the intensity of light transmitted at zero degrees.

## Suggestions

Set one Polarizer Disk at zero degrees and the second at 90 degrees. (This is called "cross-polarized".) Adjust the second

disk until the light transmitted through the disks is at a minimum. Put a small piece of polarizer material between the two Polarizer Disks, and adjust its angle until the light transmitted through the three polarizers is a maximum. Note the angle of the piece of polarizer material.

Set up the Polarizer Disks so that they are cross-polarized as before. Put a pair of sunglasses between the two polarizers and rotate the sunglasses from horizontal to vertical. Note any change in appearance of the light transmitted through the two polarizers and the pair of sunglasses.

Observe a light source through both Polarizer Disks. Set one Polarizer Disk at zero degrees and the second at 90 degrees. Next, put a clear piece of plastic between the two Polarizer Disks. Note the appearance of the clear plastic object. Flex or twist the plastic object and note any change in appearance of the object.

### Polarizer Demonstrator Accessory

The PASCO Model OS-8172 Polarizer Demonstrator Accessory works with the Polarizer Demonstrator to show the property of optical activity - the ability to rotate plane-polarized light. In 1874, the Dutch chemist Jacobus Henricus van't Hoff proposed that the tetrahedral structure of the carbon atoms in optically active materials was responsible for the behavior.

The OS-8172 includes a bottle support, two rectangular sample bottles with lids, a diffuser screen, and thumbscrews for attaching the bottle support and diffuser screen to the Polarizer Demonstrator stands.

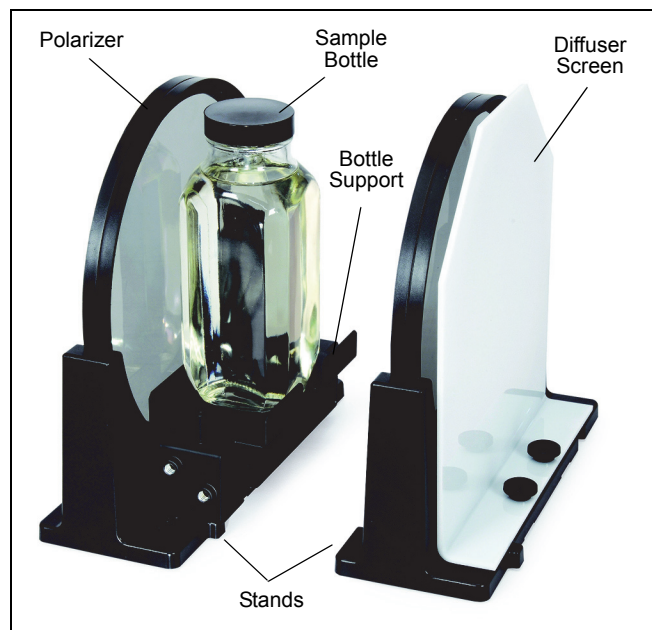

## Technical Support

For assistance with any PASCO product, contact PASCO at:

Address: PASCO scientific  
10101 Foothills Blvd.  
Roseville, CA 95747-7100

Phone: +1 916-462-8384 (worldwide)  
877-373-0300 (U.S.)

E-mail: support@pasco.com

Web: www.pasco.com

For the latest information about the Polarizer Demonstration or the replacement items and accessories, go to the PASCO web site at [www.pasco.com](http://www.pasco.com) and enter the model number in the search window.

**Limited Warranty** For a description of the product warranty, see the PASCO catalog. **Copyright** The PASCO scientific *Instruction Manual* is copyrighted with all rights reserved. Permission is granted to non-profit educational institutions for reproduction of any part of this manual, providing the reproductions are used only in their laboratories and classrooms, and are not sold for profit. Reproduction under any other circumstances, without the written consent of PASCO scientific, is prohibited. **Trademarks** PASCO, PASCO Capstone, PASPORT, SPARK Science Learning System, SPARK SLS, and SPARKvue are trademarks or registered trademarks of PASCO scientific, in the United States and/or in other countries. For more information visit [www.pasco.com/legal](http://www.pasco.com/legal).