

INSTALLATION MANUAL AND INSTRUCTIONS FOR USE



PART NUMBERS AND ACCESSORIES

Part number	Description	
487A03	Tilt & table motorized height adjustable and tilting stand travel 26”[660 mm] black max 220Lbs.(100kg) 100 – 240 V, 50 – 60 Hz	US power cable
487A03002	Tilt & table motorized height adjustable and tilting stand travel 26”[660 mm] black max 220Lbs.(100kg) 100 – 240 V, 50 - 60 Hz	EU power cable (Schuko)
481A102	Adapter set for screens with VESA 700x500, 700x600, 800x500 and 800x600	
481A103	Adapter set for screens with VESA 700x200, 700x400, 800x200 and 800x400	



General warnings:

This product is intended for installation by a trained professional (the installer), do not attempt to install the product yourself.

A correct installation of this product is extremely important for the safe and correct use of it. The installer must follow the instructions in this manual for correct installation. Not doing so may result in injury to persons or damage to equipment. The manufacturer is not responsible for and does not control the correct installation according to this installation manual.

It is the responsibility of the installer to ensure that the floor can support at least four times the combined weight of the screen plus the mounts. The maximum load for this product is specified in this installation manual.

Hardware for the correct installation of the mount and the screen is included with the product, use the supplied hardware for its intended purpose. Do not use alternative hardware before consulting with the manufacturer of the product.

Follow the mounting instructions and warnings for installation and use of the screen supplied by the screen manufacturer, make sure the weight specifications of the screen used plus other brackets and hardware is within the weight limits specified for the use of the mount.

Warranty terms and conditions:

1. Manufacturer guarantees that a product that manufacturer has determined to be defective as a result of a manufacturing or material defect will be repaired or replaced (to be determined by Manufacturer), without cost, on condition that a claim is made within the period of warranty, which is 3 years.
2. In the event of a claim being made under the terms of the warranty, the product needs to be returned to the manufacturer by the installer accompanied by a RMA form, which we will send on request. The freight costs from the installer to the manufacturer are covered under the terms of the warranty provided the RMA instructions are followed with regard to the forwarder.
3. The guarantee provided by manufacturer shall lapse or be void if:
 - a defect arises as the result of incorrect or inexpert assembly or installation.
 - in case of improper use or any use not in accordance with the instructions.
 - in case of normal wear and tear.
 - without the written consent of the manufacturer, customer or a third party have introduced changes to the product or have attempted to do so, the product has been used for anything other than its intended use or if products were processed or revised in some way other than was instructed.
 - A customer or a third party engaged by customer performed repairs without the written consent of the manufacturer.

The intended use of the product:

The product is intended to be used for the mounting and height adjustment of passive or interactive flatscreen display panels. The product is intended for in-door use in classrooms, offices or meeting rooms, at temperatures ranging between 50 and 86 °F / 10 to 30 °C.

The product is intended for use by adults; children under the age of 16 should only use the product under adult supervision.

Specifications and limitations of the product:

Maximum weight capacity:	220lbs / 100kg
Maximum screen size:	75" diagonal
Maximum slope during moving:	10 degrees

The manufacturer:

Thomas Regout Inc; 1445 Londonderry Drive
Woodstock 30188 GA USA

Regout Balance Systems B.V; Industrieweg 40
6219NR Maastricht; The Netherlands

DISCLAIMER

The manufacturer and its affiliated corporations and subsidiaries, intend to make this manual accurate and complete. However, the manufacturer makes no claim that the information contained herein covers all details, conditions or variations, nor does it provide for every possible contingency in connection with the installation or use of this product.

The information contained in this document is subject to change without notice or obligation of any kind. The manufacturer makes no representation of warranty, expressed or implied, regarding the information contained herein. The manufacturer assumes no responsibility for accuracy, completeness or sufficiency of the information contained in this document.

All rights reserved.

IMPORTANT SAFETY INSTRUCTIONS



WARNING:

Failure to read, thoroughly understand, and follow all instructions can result in serious personal injury, damage to equipment, or voiding of factory warranty! It is the certified installer's responsibility to make sure all mounting systems/ accessories are properly assembled and installed using the instructions provided.

WARNING:

Failure to provide adequate structural strength for this mounting system can result in serious personal injury or damage to equipment! It is the certified installer's responsibility to make sure the structure to which this mounting system is attached to or placed upon is flat and even and can support at least four times the combined weight of all equipment. Reinforce the structure or surface as required before installing the mounting system.

WARNING:

Use this mounting system only for its intended use as described in these instructions. Do not use attachments or accessories not recommended by the manufacturer.

WARNING:

Never operate this mounting system if it is damaged. Return the mounting system to your dealer, a service center or contact the manufacturer for examination and repair.

WARNING:

Do not use this product outdoors.

WARNING: RISK OF INJURY TO PERSONS!

Do not place video equipment such as televisions or computer monitors on cart legs. (where applicable)

WARNING:

Exceeding the weight capacity can result in serious personal injury or damage to equipment! It is the certified installer's responsibility to make sure the combined weight of all accessories and equipment attached to the 487A03 assembly up to (and including) the display does not exceed the maximum load of 220 lbs / 100 kg. Use with heavier screens may result in instability causing tip over resulting in death or serious injury! The height adjustable feature of this trolley will not function properly if the weight exceeds the given maximum load.

WARNING: RISK OF SERIOUS INJURY OR DEATH!

Placing a remote control or toy on the trolley or wall mount may encourage a child to climb onto the product causing the trolley to tip over onto the child. DO NOT place remote controls or toys on the product!

WARNING: RISK OF SERIOUS INJURY OR DEATH!

Relocating audio and/or video equipment to the trolley may result in the trolley collapsing or overturning onto a child. DO NOT relocate audio and/or video equipment to the trolley!

NOTE:

The motorized height adjustable stand or wall mount can support all kinds of screen sizes as long as the distance between floor frame and bottom screen is at least 2 inch / 50mm. The intended maximum screen size is 75" diagonal.

UNPACKING / CONTENT OF THE PACKAGING

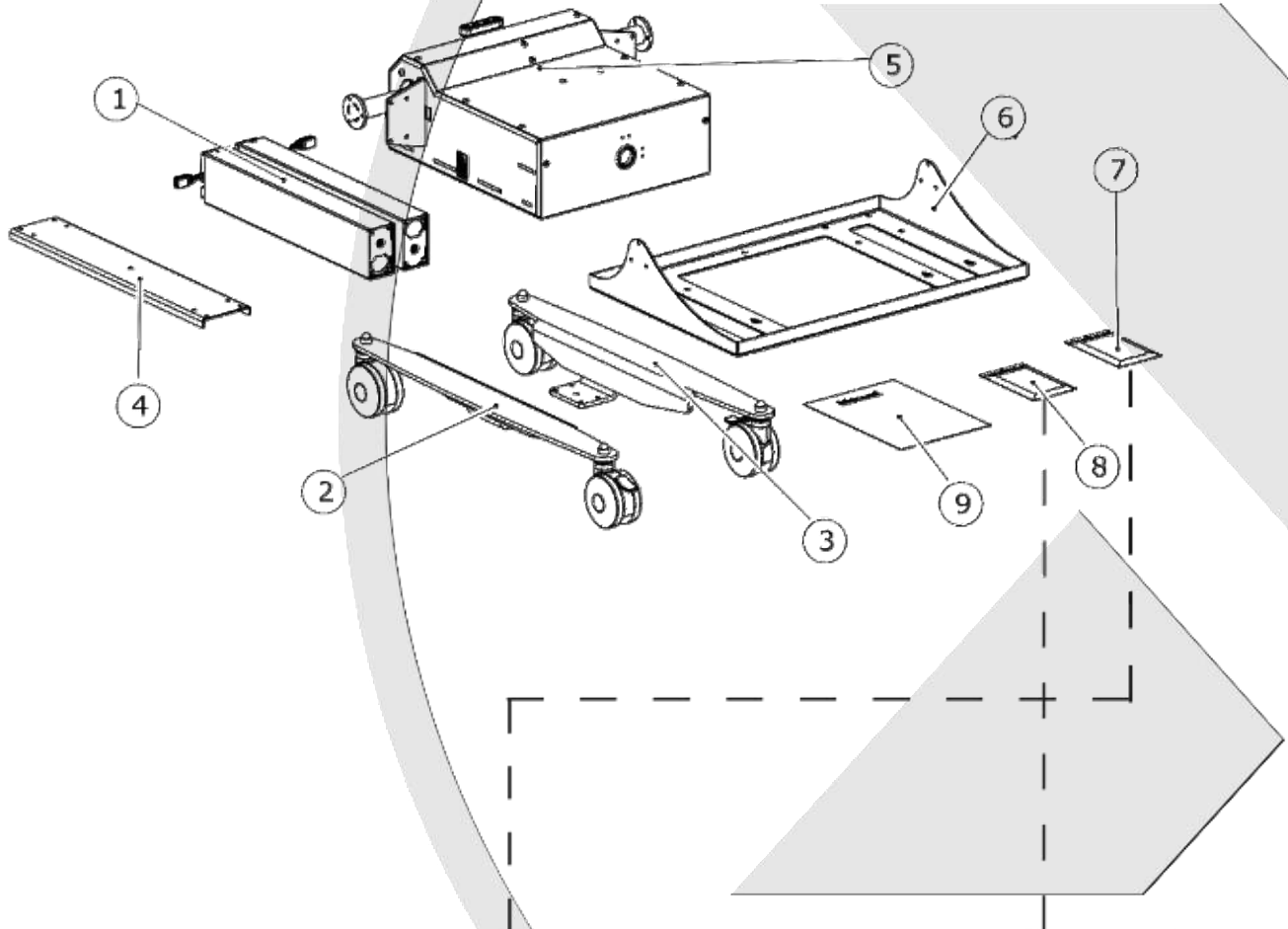
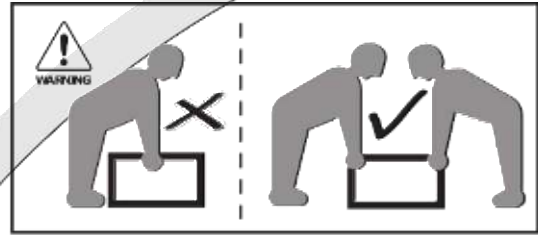

MON.0265		MON.0190	
7a M6x16 8x (2 spare)	7f 65x12x1 2x (1 spare)	8a M6x12 4x	
7b M6x20 8x	7g 300x3.6 5x	8b M6x25 4x	
7c M6x25 8x	7h #4 1x	8c M8x16 4x	
7d M5 6x		8d M8x25 4x	
7e M6 6x			

ASSEMBLY

1

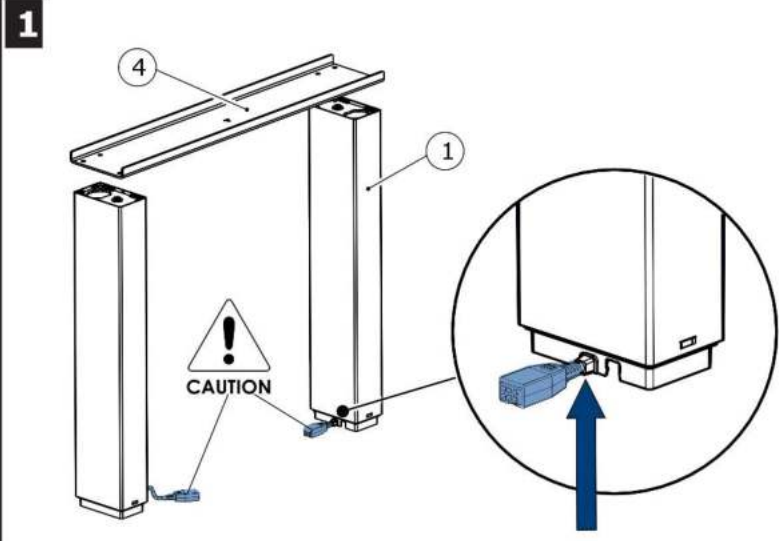

CAUTION

Carefully place the two lifting columns (1) on a flat non-scratching surface.

Make sure that the motor cable connectors are facing inward and that the cable is in the cable slot as shown.

2

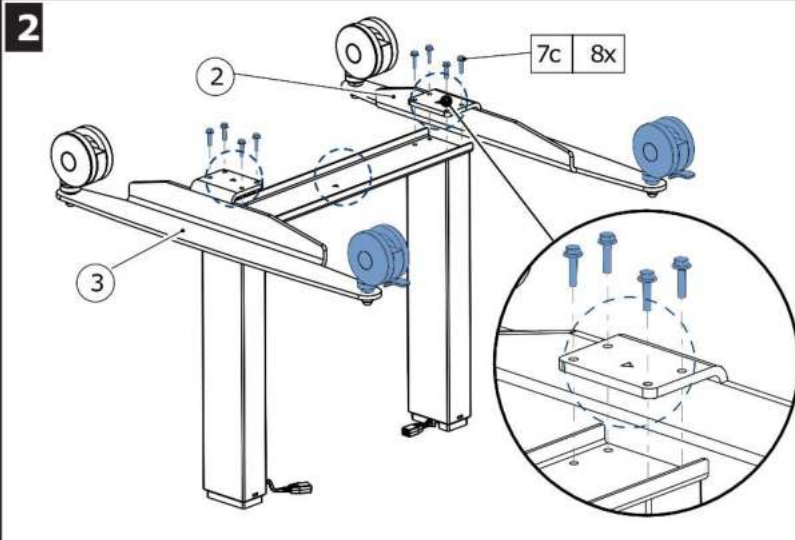

CAUTION

The screw torque must not exceed 10 Nm

WARNING

Before tightening the bolts check that all triangular markings, point in the same direction. This to make sure the wheels with brake are in front.

3

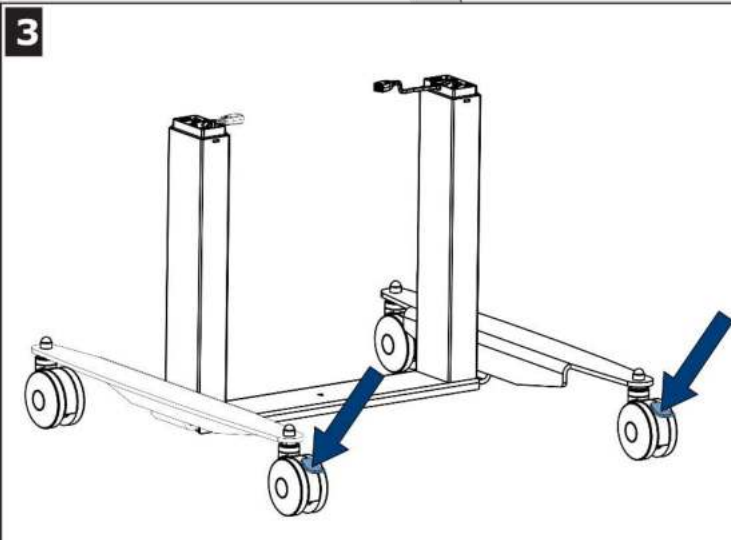

CAUTION

Carefully place the frame on its wheels and lock them both.

ASSEMBLY

4

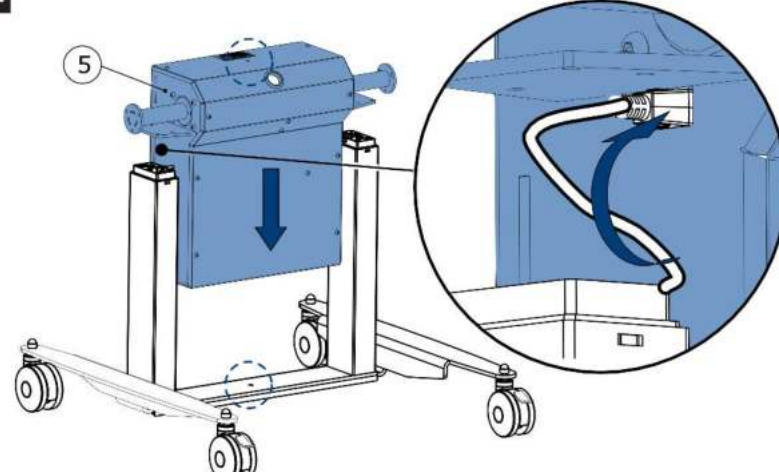

Again check that all triangular markings, point in the same direction to the front!

Maneuver the two motor cable connectors into the tilt module (5) on both sides.

5

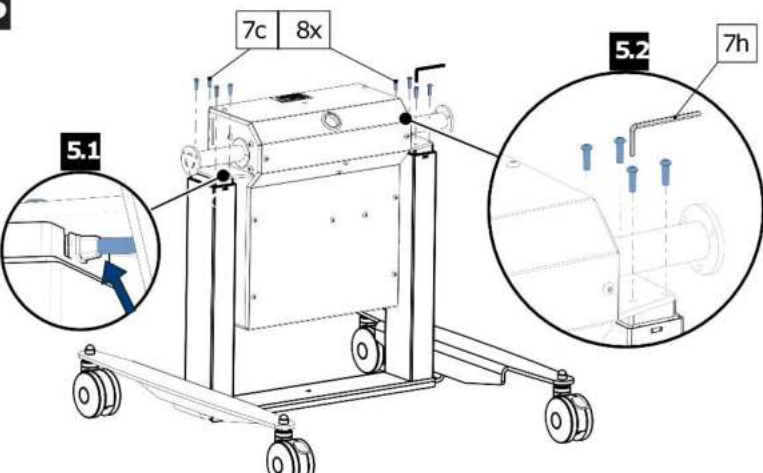

CAUTION

5.1 First check that the cables on both sides are correctly positioned in the cable slot.

5.2 The screw torque must not exceed 10 Nm

6

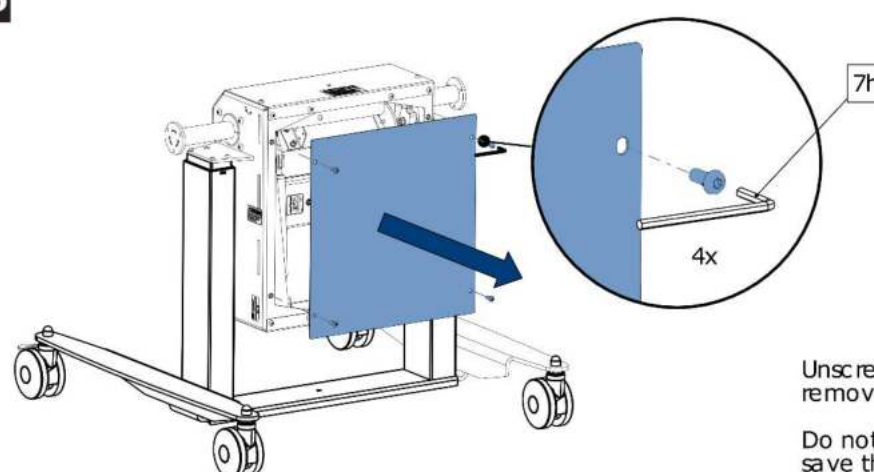

Unscrew the four bolts and remove the back cover.

Do not throw the bolts away, save them to reinstall the back cover later.

ASSEMBLY

7

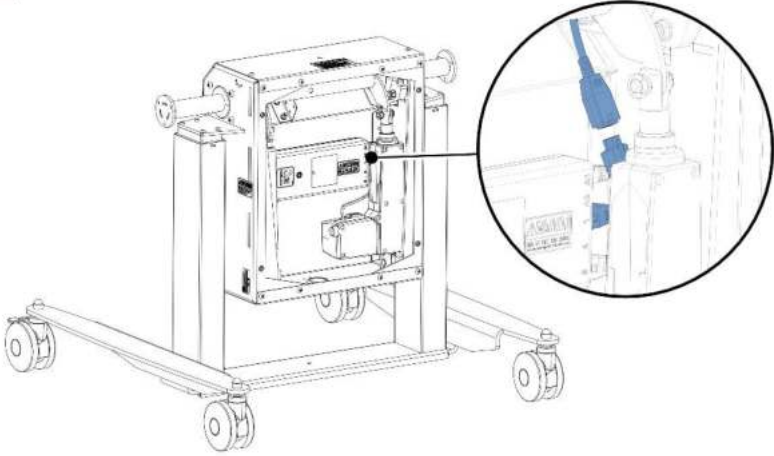

CAUTION
Connect the motor cable with the cable connected to socket "1".

It is the responsibility of the installer to ensure that the cables are connected in the right way and can't be damaged by moving parts.

8

Fix cable with tie-wrap trough two small holes.

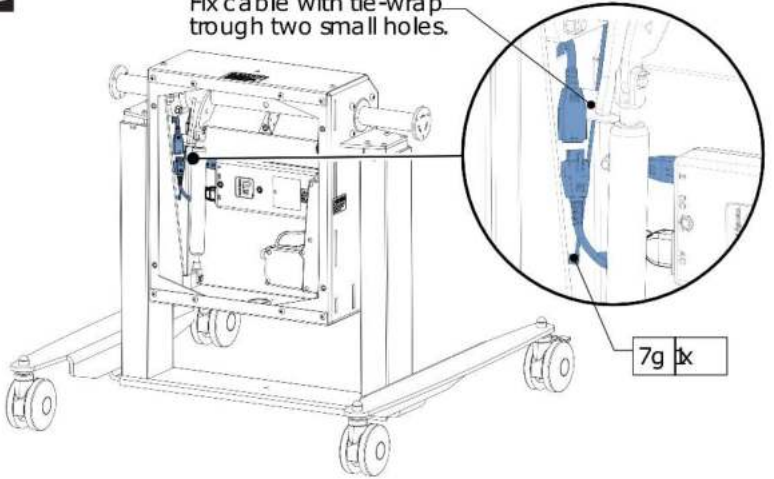

CAUTION
Connect the motor cable with the cable connected to socket "2" and fix the cable with a tie-wrap [7g] as shown.

It is the responsibility of the installer to ensure that the cables are connected in the right way and can't be damaged by moving parts.

7g 1x

9

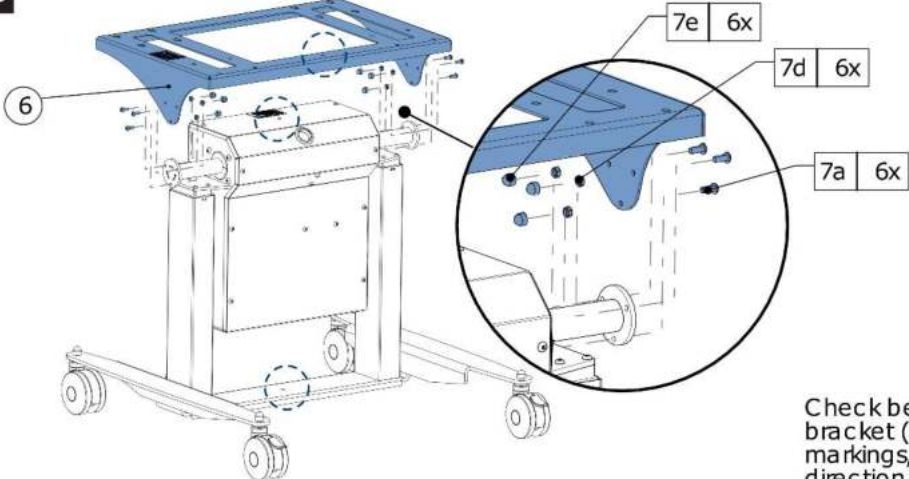

6

7e 6x

7d 6x

7a 6x

Check before mounting the bracket (6) that all triangular markings, point in the same direction to the front.

MOUNTING THE SCREEN

10

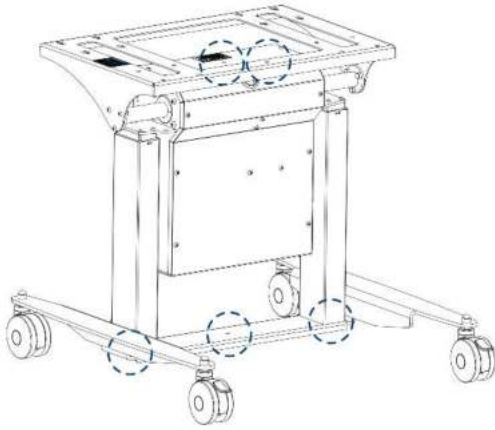

WARNING

Improper installation can lead to, the lift system to fall over causing severe personal injury or damage to equipment!
It is the installer's responsibility to make sure the combined weight of all accessories and components attached to the e-Box Tilt & table does not exceed the specified maximum load of 220 lbs (100kg)
Check that all markings point to the front!

11

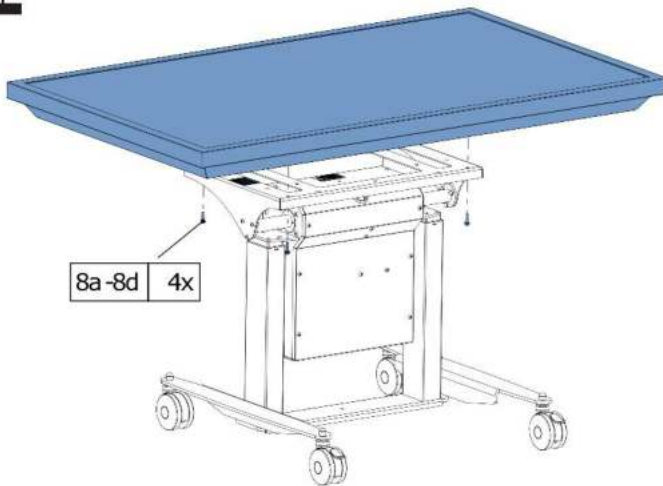

WARNING

Always lift with a minimum of two people and use proper lifting techniques when installing or mounting the display!



CAUTION

Using bolts of improper diameter or length may damage your display!

12

max.40.5" [1028.7mm]

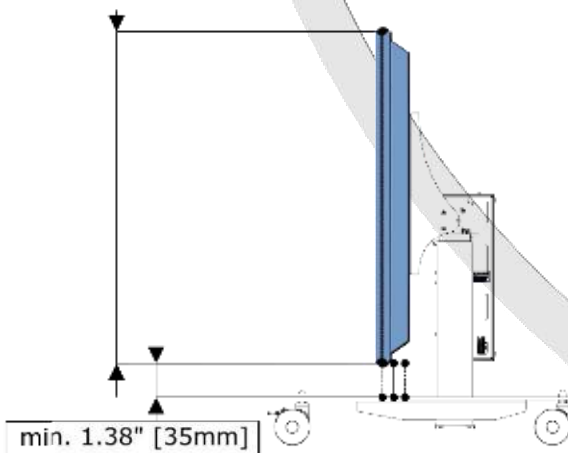

min. 1.38" [35mm]



WARNING

Overriding the given minimum and maximum distance can cause serious injury or damage to the equipment!
It is the installer's responsibility to ensure the minimum and maximum distances in all cases, including all accessories and components attached to the e-Box Tilt & table.



INSTRUCTIONS FOR USE

13

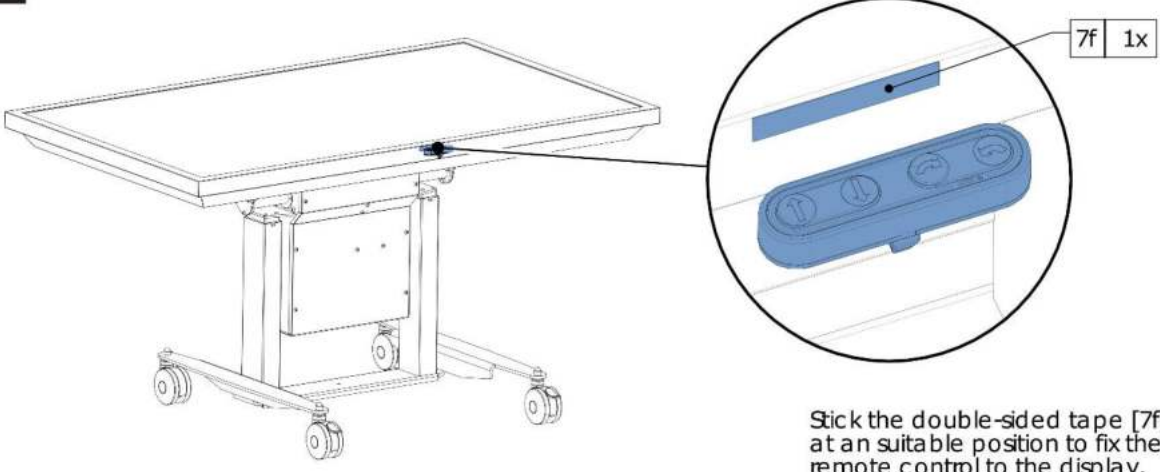

7f 1x

Stick the double-sided tape [7f] at a suitable position to fix the remote control to the display.

14

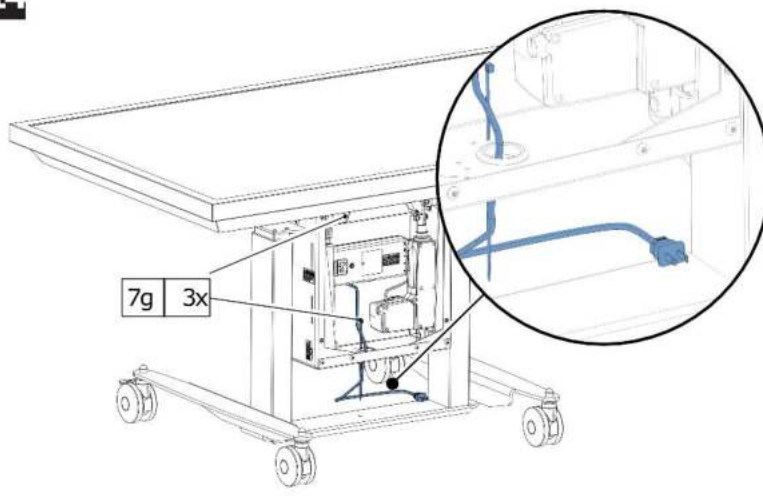

7g 3x

WARNING

Inadequate wiring and installation of electrical equipment can cause serious injury or damage to the equipment!
Its the installers responsibility to ensure the wiring and installation of all components added to the e-Box Tilt & table is according local registrations!

15

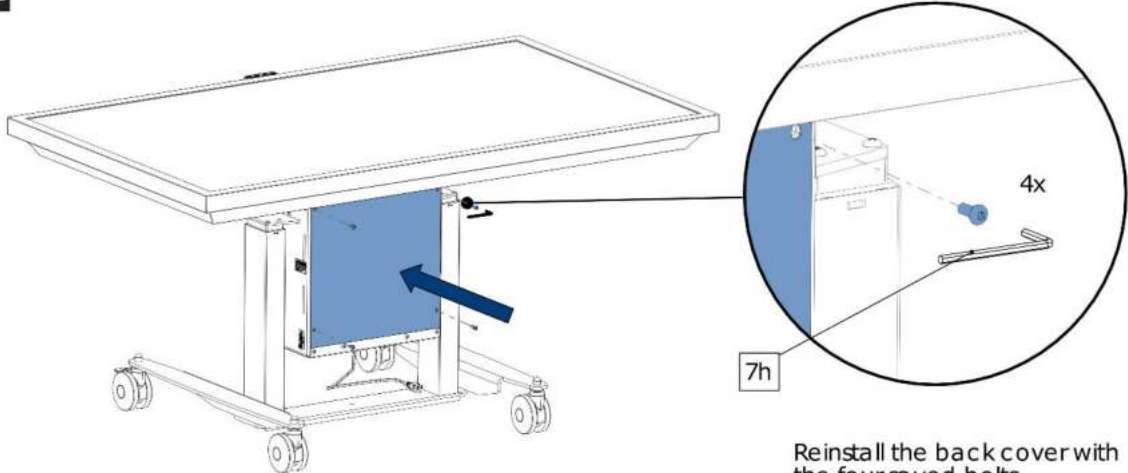

7h

4x

Reinstall the back cover with the four saved bolts.



Notes:

- Read user manual before using the equipment.
- Markings and symbols explained in the legend of this manual, page 5.

1



WARNING

Risk of serious injury or death!

1. Do not place remote controls (of 3rd party) or toys on the mobile lift system!
2. Do not relocate audio and/or video equipment to the mobile lift system!
3. Do not allow children under 16 to use the mobile lift system!
4. Always lower the display before transport!
5. Do not pull, but push! Move slowly, always push toward the middle, never apply force at top!
6. Servicing is only to be performed by an authorized service representative!
7. Before servicing disconnect mains plug!
8. Hazardous moving parts, keep fingers and body parts away!
9. Make sure the area around the lift system is clear before use!



2



WARNING

Risk of serious injury or death!

10. Do not pull down slope!
11. Always stay above mobile lift system when moving down slope!
12. Make sure the display is in lowest position!
14. Do not raise the display with the lift system on a slope!

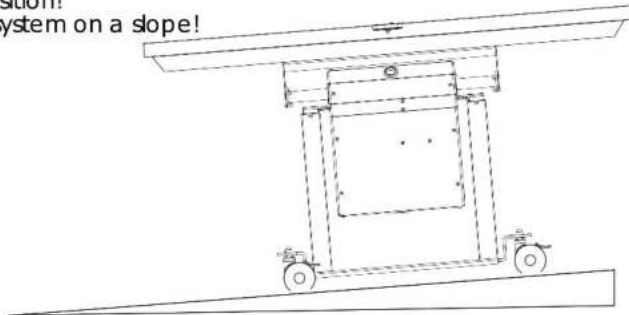

3

1. Place the e-Box Tilt & Table on a horizontal and flat surface!
2. Make sure the wheels are locked before use!
3. Insert the mains plug into the outlet.
The equipment shall be so installed that socket-outlet shall be near the equipment and shall be easily accessible.
4. Push the up button (a) to lift the display up.
5. Push the down button (b) to lower the display.
6. Push the left turn button (c) to tilt the display from horizontal to vertical.
7. Push the right button (d) to tilt the display from vertical to horizontal.

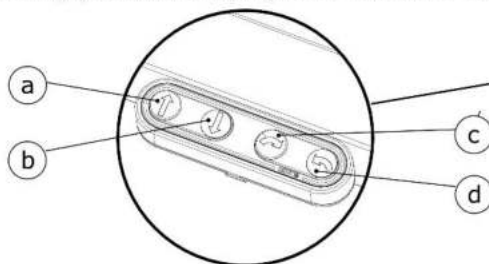
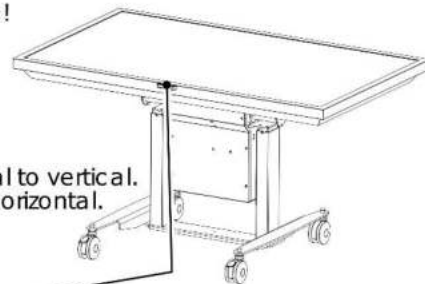

RESET CONTROL BOX – MOTOR SYNCHRONISATION

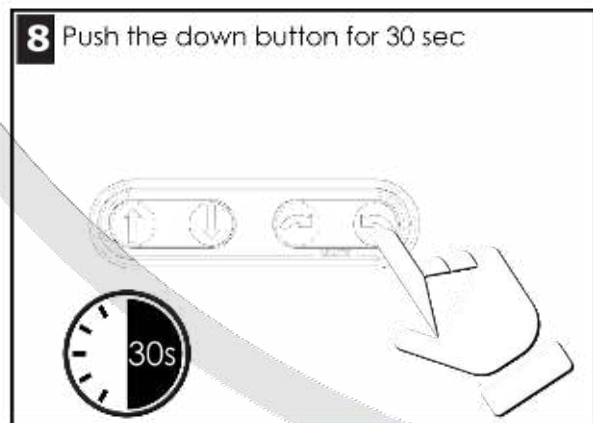
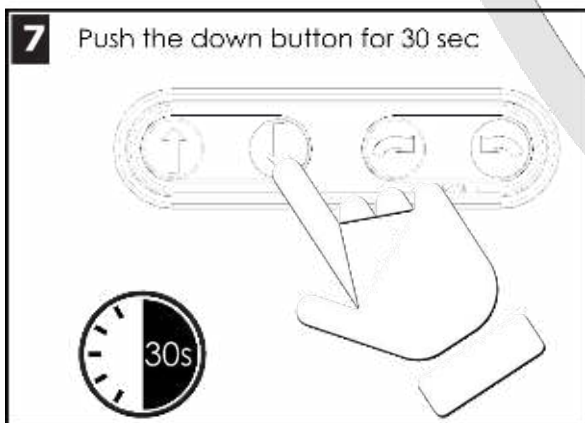
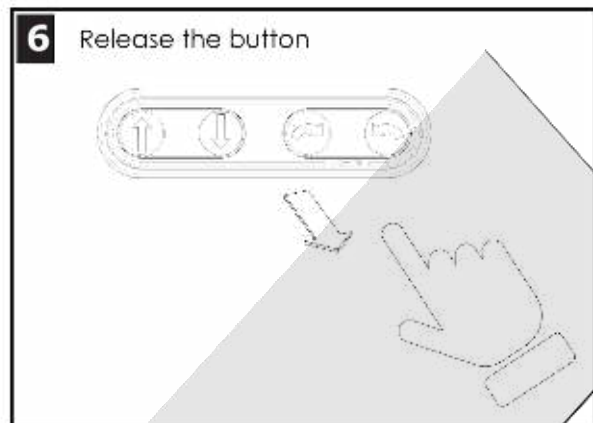
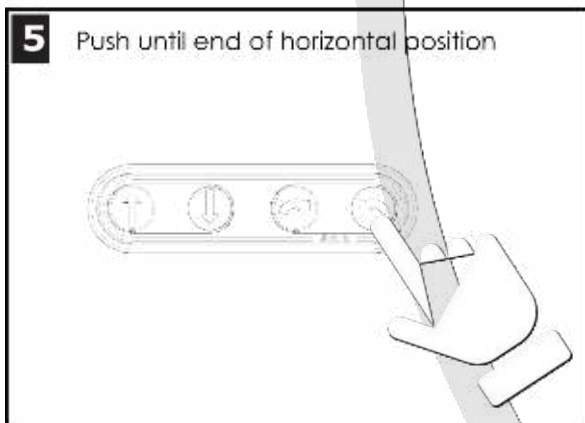
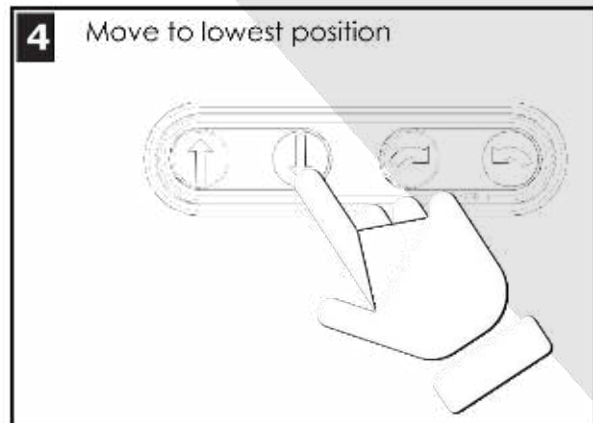
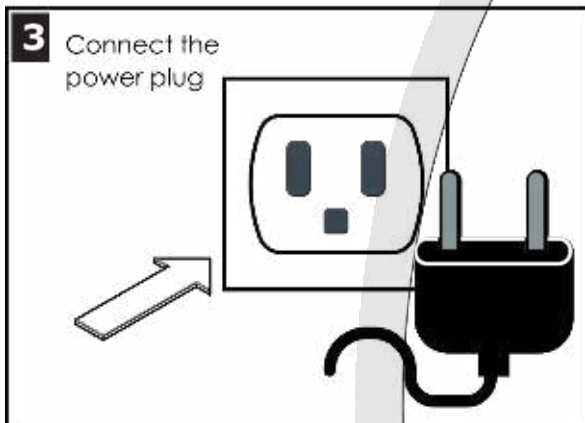
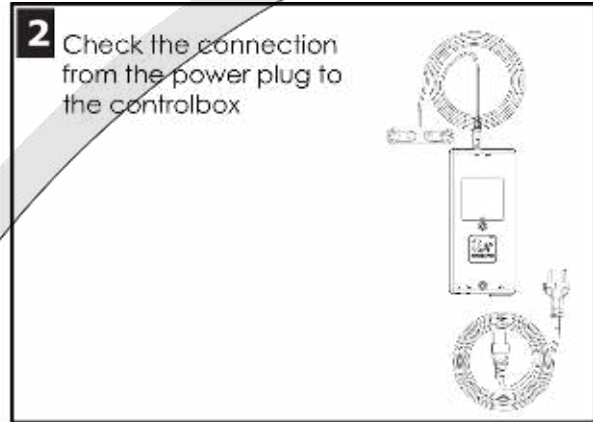
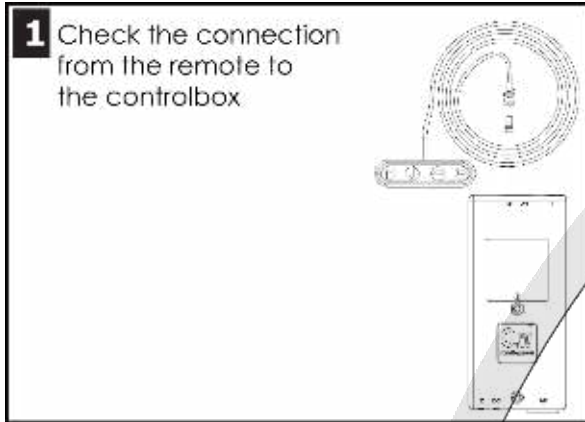

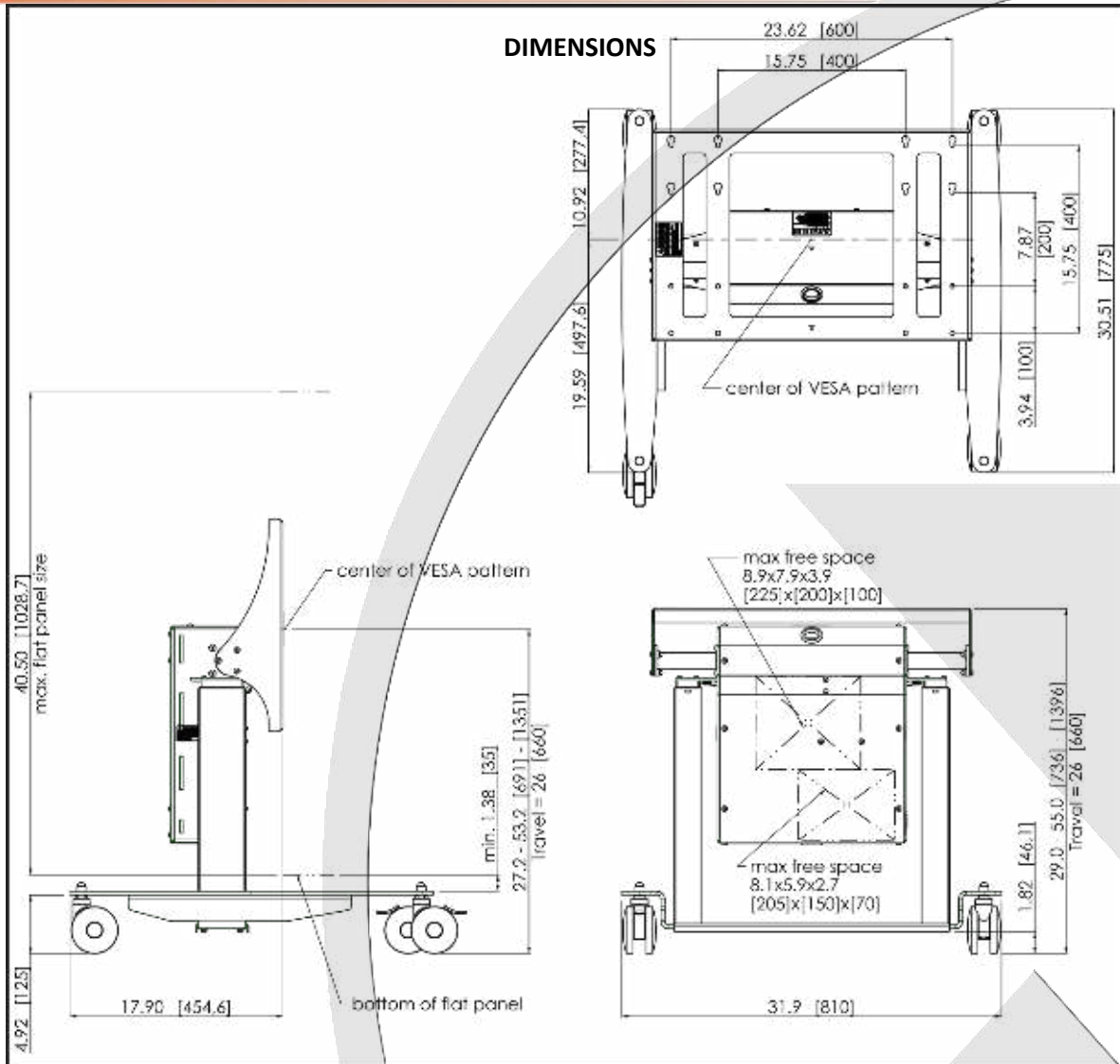

FAQ: Frequently Asked Questions

A: The e-Box® does not move up or down

- A1: Check the power lead is connected to the wall outlet, if not connect the power lead.
- A2: Check the cable connections to the control box Page 10 step 1 and 2, make sure the cables are connected.
- A3: Check the connection of the short motor cable to the control box cable, make sure the cables are connected.
- A4: Check for wiring damage from bad assembly: page 5 on step 4: If wiring is damaged, disconnect the e-Box® from the wall outlet and contact your dealer for a replacement or repair.
WARNING: DO NOT ATTEMPT TO REPAIR BROKEN WIRING!
- A5: The e-Box® motors are intended for intermittent use, continuous or extended use (more than 6 minutes) will cause over-heating and a safety system will switch the motors off, if this happens allow the motors to cool down for at least 1 hour. The system will automatically switch back to normal when the motors have cooled down.
- A6: If steps A1 to A4 have been found in order and the problem still exists, contact your dealer for repair of the unit.

B: The motors don't move smoothly or the left and right motors are at a different height

- B1: Follow steps 3 to 6 on page 10 to synchronize the motors

C: The e-Box® only moves down and not up: the e-Box went into safe-mode, a power cut may have happened during operation, or there is a bad wiring connection.

- C1: Follow the steps 3 to 6 on page 10 to synchronize the motors
- C2: If the problem still exists follow steps A1 to A4

RJ45 CONNECTION DIAGRAM

RJ45 - 8 PIN CONNECTION DIAGRAM

WARNING:

The height adjustable mount can only be operated remotely when visual supervision of the moving products is possible. Operating the product without visual supervision may result in serious injury or death.



Cable wire color	Function	RJ45 8 Pin plug no.
Blue + Green	Reference 1 Up	RJ45 Pin 4 + 5
Blue + Red	Reference 1 Down	RJ45 Pin 4 + 8
White + Green	Reference 2 Up	RJ45 Pin 3 + 5
White + Red	Reference 2 Down	RJ45 Pin 3 + 8
Orange + Green	Reference 3 Up	RJ45 Pin 2 + 5
Orange + Red	Reference 3 Down	RJ45 Pin 2 + 8

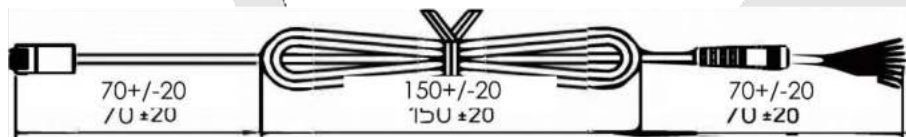

L = 1700 mm +/- 70 mm

